





BESTE EGONALDIAK: JATORRIA, ATZERRIKO UNIBERTSITATEA (208.2.2.1)

Doktoregai bisitaria 	UPV/EHUko gainbegiralea 	Doktorego programa hartzailearen batzorde akademikoa 	Doktorego Eskola DOKE	UPV/EHUko zentro/campus hartzailea 
--	--	---	---------------------------------	--

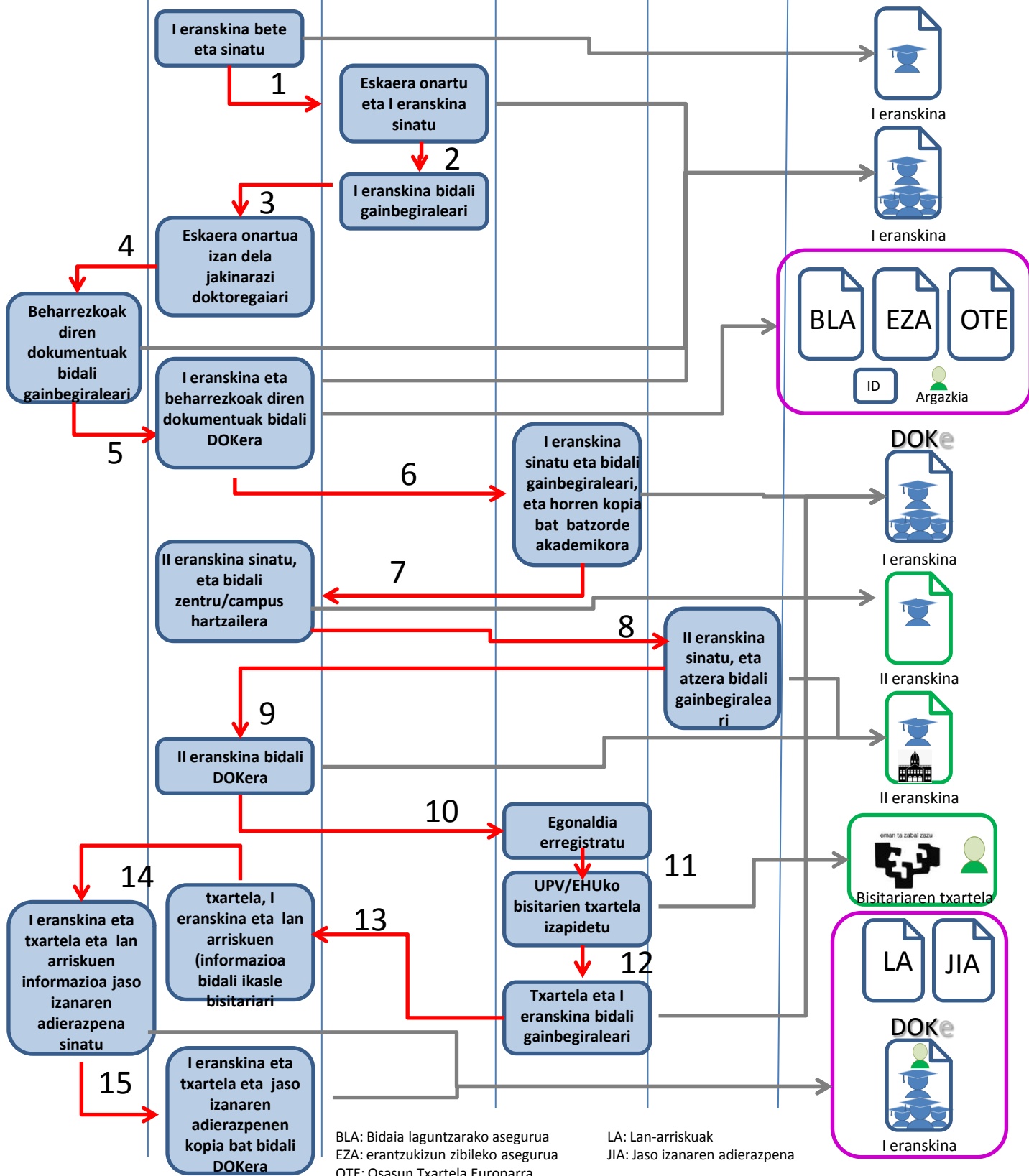

BLA: Bidaia laguntzarako aseguruua
 EZA: erantzukizun zibileko aseguruua
 OTE: Osasun Txartela Europarra

LA: Lan-arriskuak
 JIA: Jaso izanaren adierazpena

BESTE EGONALDIAK: JATORRIA, UPV/EHU (208.2.2.2)

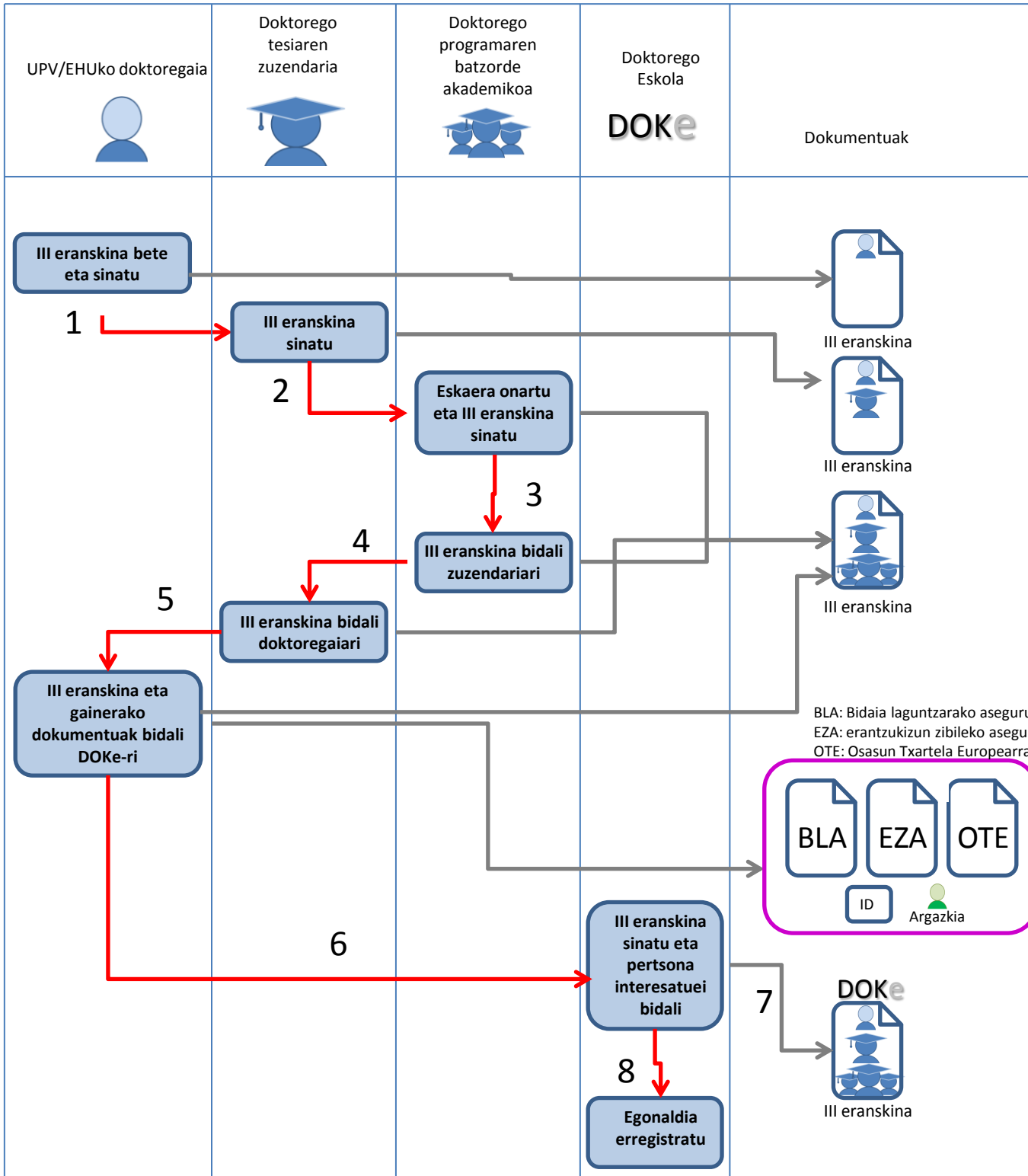

Egonaldia amaitutakoan, doktoregaiak egin behar du egonaldiari buruzko txosten bat, eta hau atxikiko da, horri dagokion ikasturteko jardueren dokumentuan. Gainera, doktoregaiak eskatu beharko dio erakunde hartzaileari egonaldiaren ziurtagiria.